



## Signal Detector Operation Guide



## EnerPulsar Anti - Islanding Signal Detector

Islanding occurs when a portion of the distribution system becomes electrically isolated from the remainder of the power system, yet continues to be energized by distributed generators (DG). Failure to trip can damage distributed generators, connected loads and can cause a safety hazard to utility transmission line workers as well as the general public.

The EnerPulsar Anti-Islanding Signal Detector is equipped at the DG site to detect the Anti-Islanding signal generated by the EnerPulsar Anti-Islanding Signal Generator. The Signal Generator is installed at the substation to provide the Anti-Islanding signal to multiple DG sites. If the detector cannot sense the signal, the DG is considered isolated from the local substation, and the DG is disconnected from the grid.

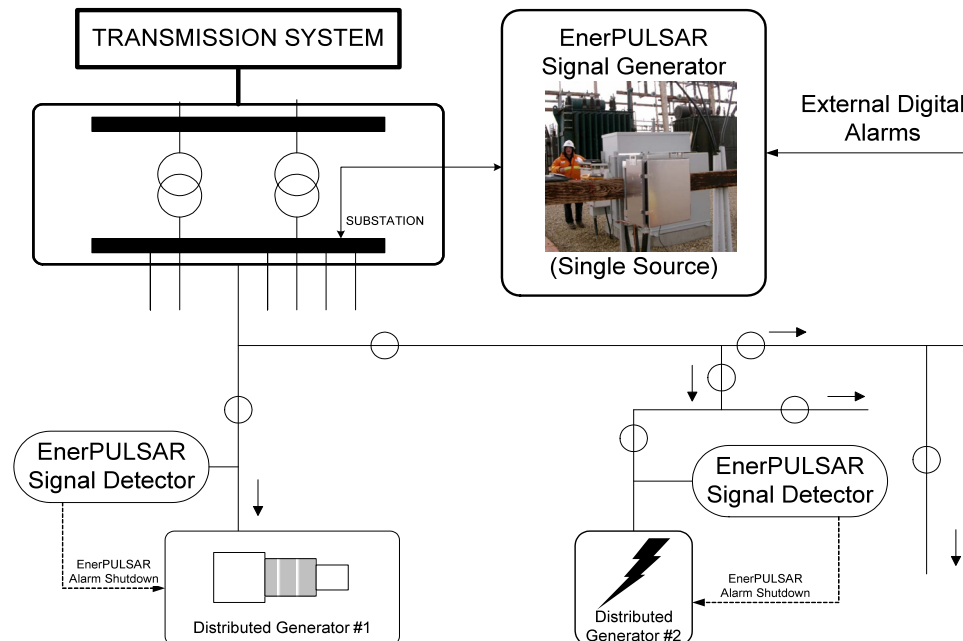

*The EnerPulsar Anti-Islanding Signal Detector provides secondary DG protection. It integrates over-voltage / under-voltage detection and over-frequency / under-frequency detection to disconnect the DG from the distribution system when required...*

### **EnerPulsar Signal Detector Main Features**

- Simple, low-cost installation & maintenance-free use.
- Works for any type of distributed generator such as wind, solar, bio-gas, natural gas, ethanol, small hydro, fuel cells, tidal, etc.
- Detects all types of islanding with no non-detection zone (NDZ).
- Set points of voltage, frequency and Anti-Islanding signal are programmable.
- Includes a field adjustable delay that can control the reconnection of distributed generators, following a temporary outage.
- Lockout function of Signal Detector prevents the DG from falsely reconnecting to the power system during a permanent fault condition; only the utility can restart the DG Signal Generator.
- The RS485 port is compatible with Modbus RTU devices allowing communication with SCADA systems and/or local control / monitoring equipment.

### **EnerPulsar Signal Detector Circuit Operational Description**

The EnerPulsar Anti-Islanding Signal Detector monitors the system three-phase and phase-to-ground voltage at the DG interconnection transformer low voltage terminals. Primary functions of the Signal Detector include:

- Anti-Islanding detection (Refer to Table 2)
- Over/Under voltage detection (Refer to Table 3)
- Over/Under frequency detection (Refer to Table 4)

The system is 'healthy' when the system voltage and frequency are in normal operating range and the Anti-Islanding signal is present.

If the system voltage and/or frequency reach the protection set-points or the Anti-Islanding signal cannot be sensed, the Signal Detector will de-energize 'Relay1' within the specified trip times. NO or NC contacts from Relay1 can be used to trip the DG as required.

## EnerPulsar Signal Detector Circuit Description

The Signal Detector has 16 terminals, as shown in Figure 1, the function of each terminal is described below:

**Figure 1 - EnerPulsar SD Terminal Functions**

### **(1 & 2) Modbus RS485**

Terminal 1 and 2 are communication ports which are used to connect a supervisory computer, data acquisition (SCADA) system, or other types of control systems that are compatible with Modbus RTU mode.

### **(4, 5 & 6) 24V Three-phase Voltage Input**

Terminals 4, 5, and 6 monitor phase A, B, and C voltages with respect to terminal 3 ground, coming from three single-phase Potential Transformers (PT). The three-phase voltages are the main inputs to the microprocessor for the Anti-Islanding signal generated by EnerPulsar Signal Generator. These inputs are also used for over/under frequency and voltage measurements. The recommended PT connection is Wye-Ground to Wye-Ground. The nominal operating voltage is 24V, and the maximum voltage is 28V.

### **(7 & 8) 24V Power Supply**

Terminal 7 supplies 24Vdc power to the Signal Detector and Terminal 8 supplies 24Vac power to the Signal Detector. Either one of the two terminals (not both) can be used in the field depending on the availability of AC or DC power.

### **(3) Ground**

Terminal 3 is the Ground point. It is connected to the PT low voltage side ground, 24V AC (or DC) power supply ground, and the internal circuit ground.

### **(14, 15 & 16) System Healthy (Relay 1)**

If the system voltage and frequency are in normal operating range and the Anti-Islanding signal is present, Relay 1 will be energized. If the system voltage and/or frequency reach the protection set points, Relay 1 is de-energized and the DG is disconnected from the distribution system immediately. Voltage / frequency protection is optional; it is not required for standard anti-islanding protection.

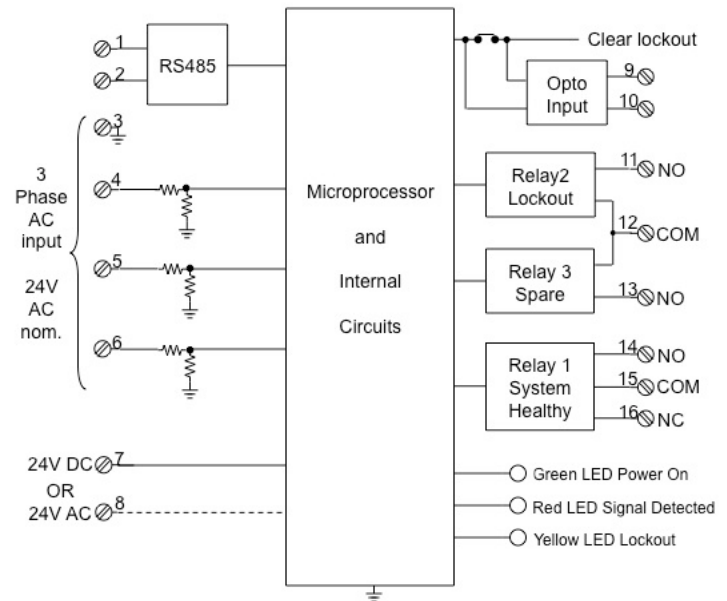

### **(14, 15 & 16) System Healthy (Relay 1) ... Cont**

Following an outage, if the system voltage and frequency restore to normal operating range and the Anti-Islanding signal is sensed within the specified 'Reconnection Delay Time' (refer to Table 5), Relay 1 will be re-energized and the DG will be re-connected

### **(11 & 12) OptoMosfet No-Lockout (Relay 2)**

A lockout condition occurs when the Signal Detector detects the system is not restored to normal operating range for more than 20 minutes (Refer to Table 5 and 6).

### **(13 & 12) OptoMosfet Spare (Relay 3)**

This relay is not used for standard operation of the signal detector.

### **(9 & 10) Clear lockout**

Terminal 9 and 10 provide an isolated input for the Reset Lockout function. When a 24V AC or DC voltage is applied between terminal 9 and 10, the lockout function is cleared. Lockout function can also be manually cleared by pressing 'RESET' button.

### **EnerPulsar Signal Detector User Operation**

When the Signal Detector is operating, three LEDs show the current status of the Signal Detector, with the different operating scenarios are summarized below and in Table 1.

- The 'POWER' LED (Green) is On when the Signal Detector is running. It is Off when the Signal Detector loses power.
- The 'SIGNAL DETECTED' LED (Red) is On when the Anti-Islanding signal is detected. It is Off when the Signal Detector cannot sense the Anti-Islanding signal.
- The 'LOCKOUT' LED (Yellow) is On when the Signal Detector is locked out.
- Lockout function can be manually reset by pressing the 'RESET' button.

**Table 1: Operating Scenarios**

POWER LED	SIGNAL DETECTED LED	LOCKOUT LED	DESCRIPTION
Off	-	-	No power
On	Off	Off	SD is running and Anti-Islanding signal cannot be detected.
On	On	Off	SD is running and Anti-Islanding signal is detected.
On	Off	On	SD is locked out. After the system is restored, press the 'RESET' button to clear lockout.
On	On	On	SD is locked out, and Anti-Islanding signal is detected.

## EnerPulsar Signal Detector Installation Notes

The EnerPulsar Anti-Islanding Signal Detector is installed at the low voltage side (for example, 600V) of the DG interconnection transformer. Three-phase voltages steps down from 347V (phase to neutral) to 24V and is applied to terminals 4, 5, and 6.

The 24V power supply can be either DC or AC depending on their availability. The 24V DC power supply should be connected to terminal 7 while 24V AC power supply should connect to terminal 8. **Do not apply power to both terminals.**

The RS485 terminals 1 and 2 along with terminal 3 Ground connect Modbus RTU mode devices to communicate with SCADA, or other local control / monitoring equipment. RS485 to RS232 convertors are available to connect to a laptop if native RS485 is not available.

A spreadsheet, utilizing VBA language, is available, to implement the Modbus RTU mode. All setpoints and live values may be viewed and changed from within the spreadsheet software.

**Figure 2 - EnerPulsar Signal Detector System Connection Schematic**

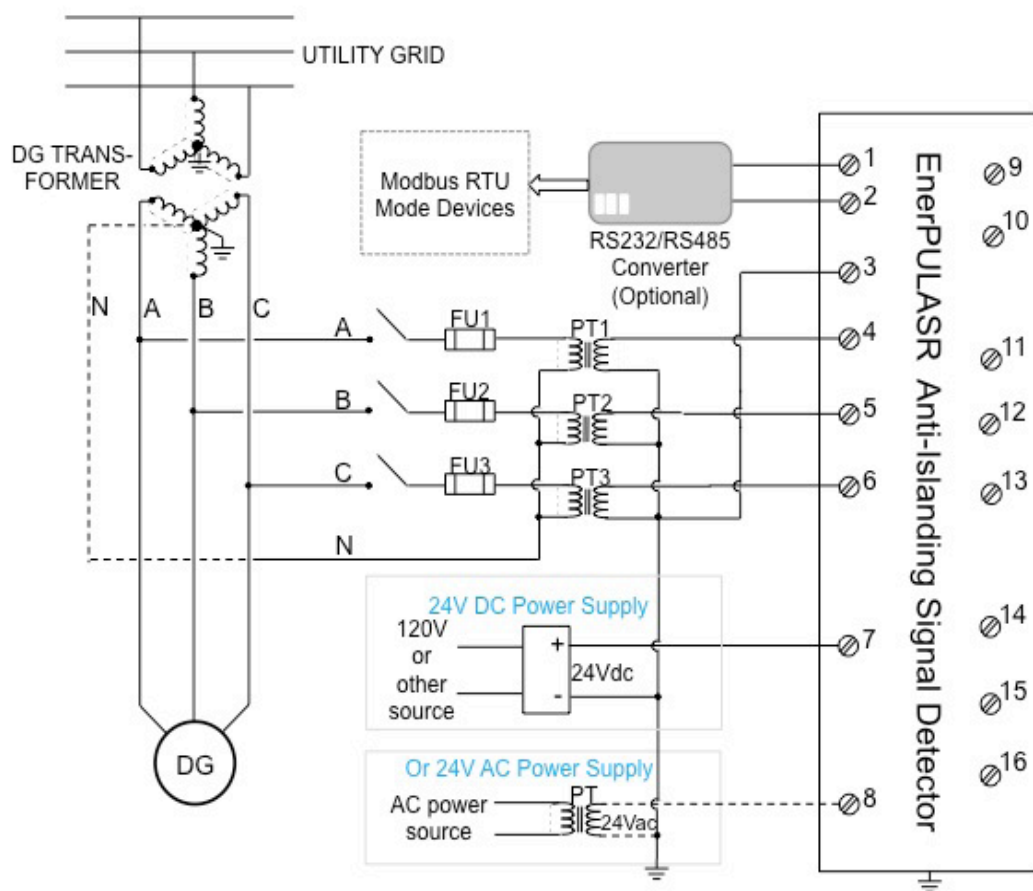

## EnerPulsar Signal Detector Specifications

Dimensions:	1.7"W x 2.8"H x 4.1"D	
Shipping Weights:	0.36 lb	
Power Supply:	24V AC or DC	
Temperature:	-40°C to 75°C	
Relay Contacts:	Relay 1:	250Vac/30Vdc, 8 Amps
	Relay 2:	250Vac/dc, 0.1 Amps
	Relay 3:	250Vac/dc, 0.1 Amps

### Signal Detector Default Settings:

**Table 2 Anti-Islanding Protection Setting<sup>1</sup>**

Anti-Islanding Signal	Trip time
Signal is missing	5 continuous signal period (or 20 cycles)

**Table 3 Over/Under Voltage Protection Setting<sup>1,2</sup>**

Voltage Range (% of base voltage)	Trip time (s)
$V < 50$ or $V \geq 120$	0.16
$50 \leq V < 88$	2.00
$110 < V < 120$	1.00

**Table 4 Over/Under Frequency Protection Setting<sup>1,2</sup>**

Frequency Range (Hz)	Trip time (s)
$f < 57.0$ or $f > 60.5$	0.16
$f < (59.8 - 57.0)$	Adjustable 0.166 – 300, comply with NPCC Directory D2 Requirement

**Table 5 DG Reconnection Requirement<sup>1,2</sup>**

Frequency Difference (Hz)	Voltage Difference (% of base voltage)	Delay Time
0.5	6	5 minutes

**Table 6 Signal Detector Lockout Time<sup>1</sup>**

Default <sup>2</sup>	Min	Max
20 minutes	15 minutes	60 minutes

<sup>1</sup> Preliminary set point, subject to change.

<sup>2</sup> Source: Hydro One Networks Inc. Distributed Generation Technical Interconnection Requirement – Interconnections at Voltages 50kV and Below

For more information on these or other  
products & services email us at:

[sales@enertiaengineering.com](mailto:sales@enertiaengineering.com)



Unit #105, 117 Pembina Road  
Sherwood Park, AB, Canada  
T8H 0J4

**Phone:** 780-467-0303  
**Toll Free:** 866-796-0303  
**Fax:** 780-401-3519

7 Cedar Street, Suite 203  
Sudbury, ON, Canada  
P3B 4H5

**Phone:** 705-693-4829  
**Toll Free:** 1-877-693-482

627A Aljunied Road  
#04-01 BizTech Centre  
Singapore 389842

**Phone:** (65) 64814106