



Utilities Presentation

Driven by Energy...

A Presentation to Utility Companies

A Power Line Signaling Based DG Anti-islanding Protection Scheme

Presented
by

Wilsun Xu, P.Eng. F.IEEE
wxu@ualberta.ca
University of Alberta
Edmonton, Alberta

February 2008

The Main Idea

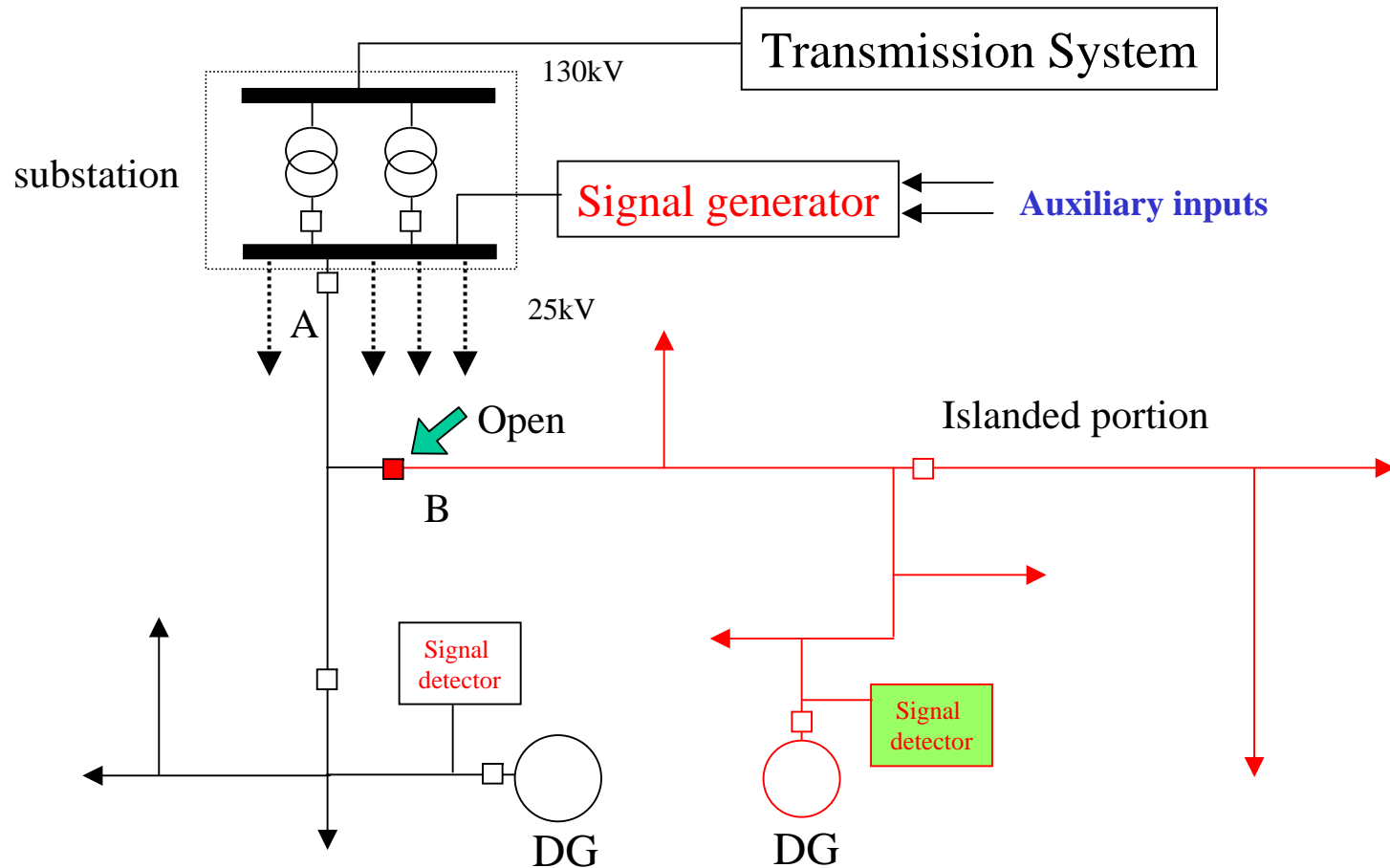

- A signal generator (SG) sends pulse signals to downstream feeders
- Signal detectors (SD) are installed at the DG sites
- If a signal detector cannot detect the signal, it is considered as islanded from the system

Operating principle

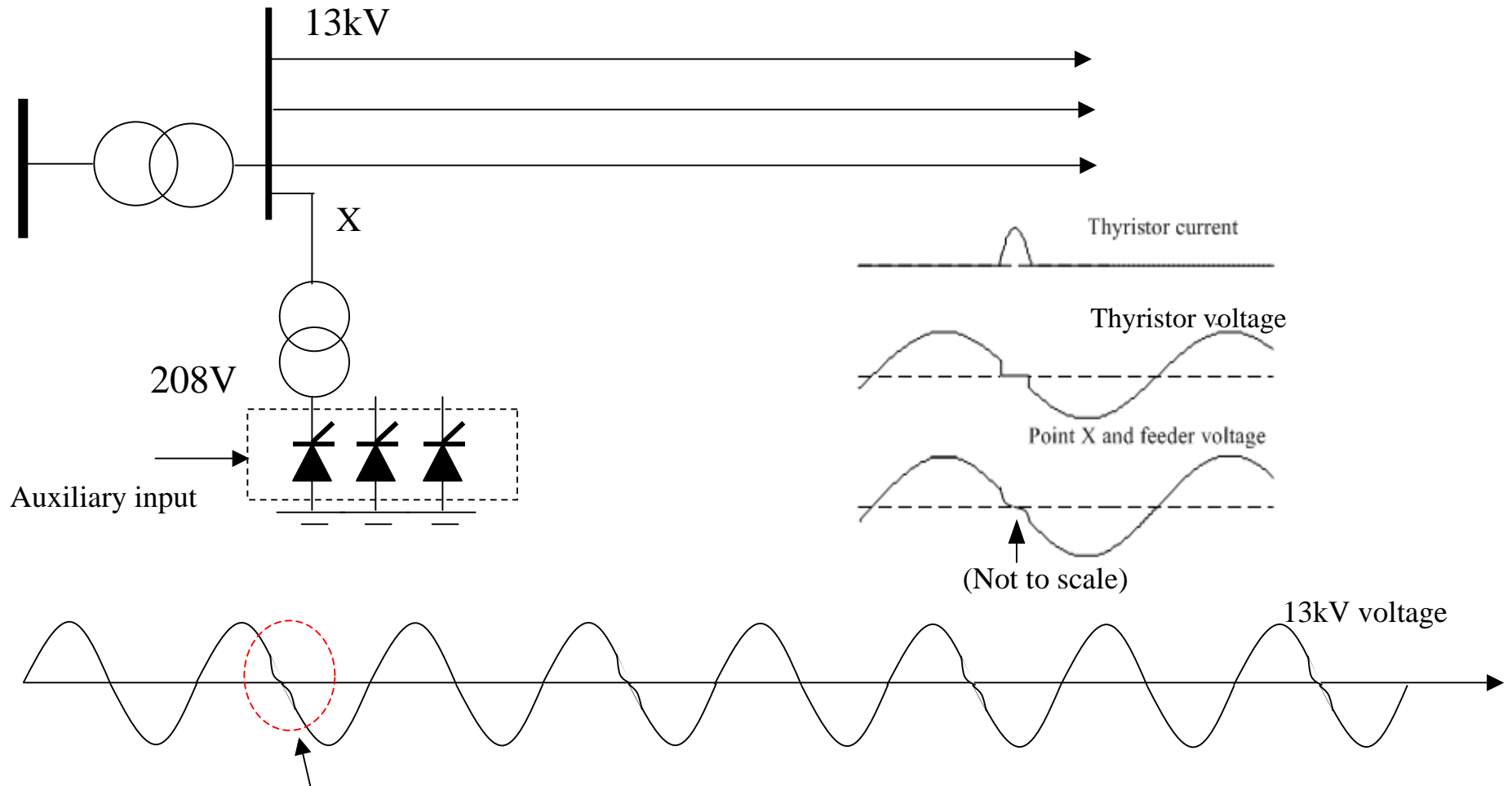

The thyristor conducts for a short period around the zero crossing point.
The resulting voltage distortion is the signal.

Sample signals

Sample field measurements

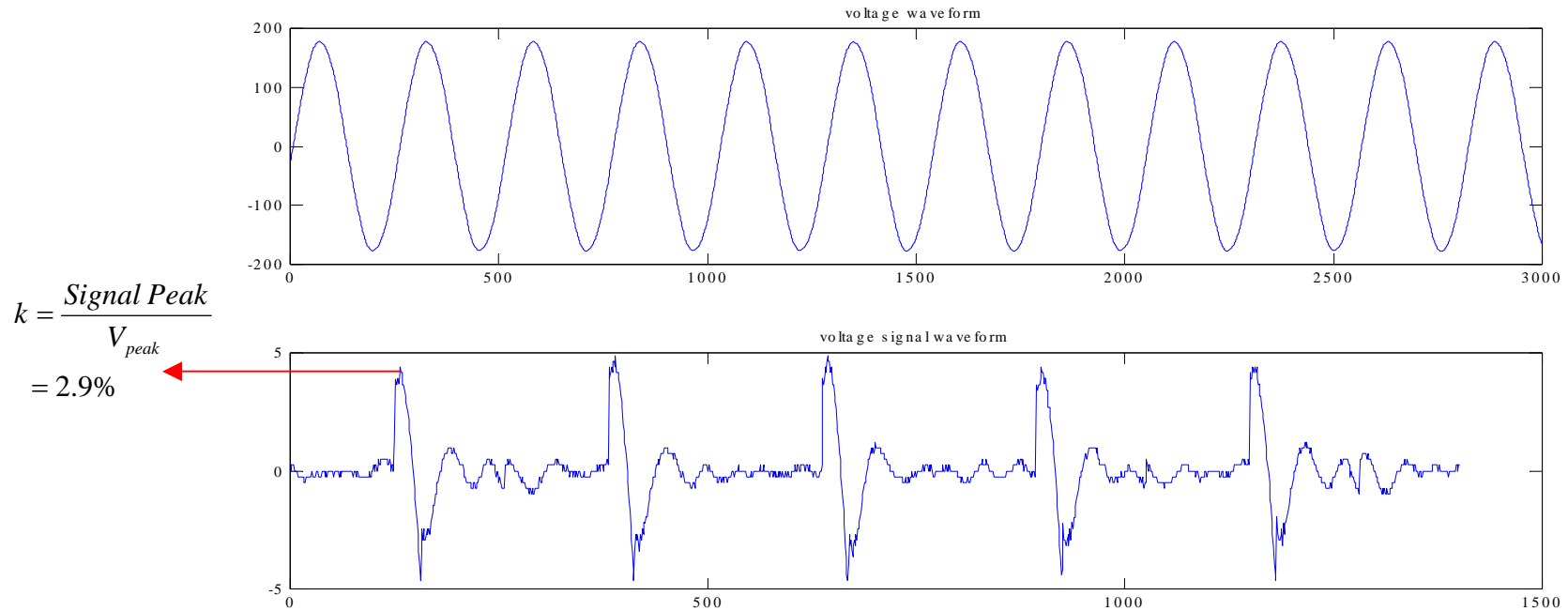

The signals are obtained by subtracting two cycles of voltage waveform where one cycle contains the voltage sag and the other does not. The result of subtraction is the voltage signal. Furthermore, **the harmonic distortions are subtracted out, leading to a signaling scheme immune to harmonics**

The signal detection algorithm can be implemented into existing programmable relays

About signal propagation

- The signaling scheme was invented more than 20 years ago at Emerson Electric. It is called TWACS (Two Way Automatic Communication System) Technology
- At present, TWACS is the most widely used PLC (power line communication) technique for MV distribution systems with applications include AMR, load control and so on
- The technology is currently marketed by Aclara (formally DCSI), whose most recent customer is PG&E which has more than 5 million metering (i.e. signal detector) points
- The widely deployed AMR applications have shown that signal attenuation is not a concern for power distribution systems

About signal propagation – TWACS experience

TWACS Technology

Web [Images](#) [Maps](#) [News](#) [Video](#) [Gmail](#) [more](#) ▼

 TWACS Search [Advanced Search](#)
[Preferences](#)

Search: the web pages from Canada

Web

[TWACS.com is now AclaraTech.com](#)
A two-way communications device that uses existing power lines to communicate with gas, water, and electric customers. System equipment and capabilities, ...
[www.twacs.com/](#) - 2k - [Cached](#) - [Similar pages](#)

[Aclara](#)
Aclara is the name that redefines one of North America's leading advanced utility communications providers, the ESCO's Communications Segment of ESCO ...
[www.aclaratech.com/](#) - 23k - [Cached](#) - [Similar pages](#)

[\[PDF\] TWACS XM & XMP](#)
File Format: PDF/Adobe Acrobat - [View as HTML](#)
TWACS is a registered trademark of DCSI. (c) 2007 Distribution Control Systems, ... All TWACS transponders support real-time Consumption and ...
[www.aclaratech.com/AclaraPLS/specsheets/4264_1_0_XM_XMP%20low%20rez%20062807.pdf](#) - [Similar pages](#)
[More results from www.aclaratech.com »](#)

[Wiglaf Journal - TWACS® Attacks AMR Market](#)
(See Changing Business Requirements Shifts Value Demand) The TWACS solution by DCSI is a well received within the AMR market. What makes the TWACS solution ...
[www.wiglafjournal.com/Articles/2003/2003-11-12-TWACS-Attacks.htm](#) - 29k - [Cached](#) - [Similar pages](#)

[\[PDF\] PowerPoint Presentation](#)
File Format: PDF/Adobe Acrobat - [View as HTML](#)
TWACS System Overview. DCSI Load Control Product. Capability. Applications Small population of traditional TWACS two-way devices ...
[www.alca.info/Contents/library/TWACS%20ALCA%20update%20April%202005.pdf](#) - [Similar pages](#)

[TWACS by DCSI | Company Profile | Electric Energy T&D Buyers Guide](#)
TWACS® by DCSI is a proven power line and radio frequency communication system with ... Over 235 utilities rely on proven TWACS® fixed network technology to ...
[www.eetdbuyersguide.com/detail_entreprise.asp?No_Entreprise=14507&IDGrande_Rubrique=1](#) - 47k - [Cached](#) - [Similar pages](#)

[www.metering.com | TWACS Operation Center to be released in new year](#)
20 Dec 2007 ... metering.com - Utility News and Information: TWACS Operation Center to be released in new year.
[www.metering.com/node/11325](#) - 40k - [Cached](#) - [Similar pages](#)

[TWACS AMIgo System Exploits Parallelism Inherent in Electrical Grid](#)
7 Oct 2005 ... The TWACS system already has the proven ability to communicate concurrently on multiple electrical phases and to exploit other elements of ...

Main attractions - 1

- Anti-islanding detection becomes the detection of signal continuity from substation to the DG location
- This scheme can also be viewed as a transfer trip scheme. But the power line is used as the signal carrier
- As a result, the scheme works equally well for feeders with multiple reclosers, significantly simplifying the radio-based transfer trip scheme
- One signal generator is sufficient to cover all DGs served by a substation

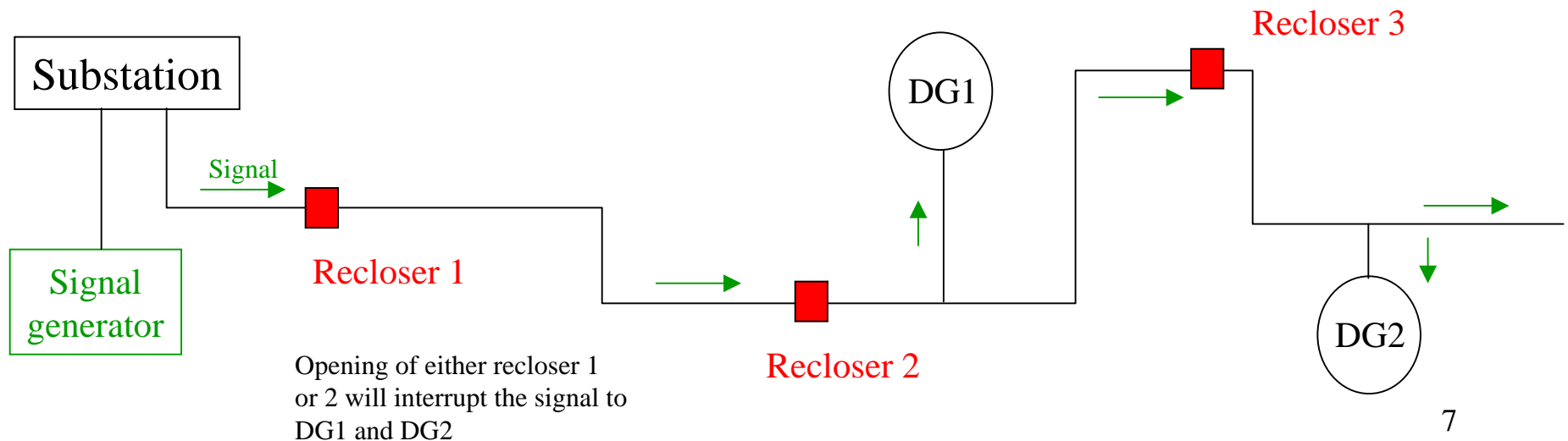

Main attractions - 2

- The scheme is also immune to the impact of feeder reconfiguration

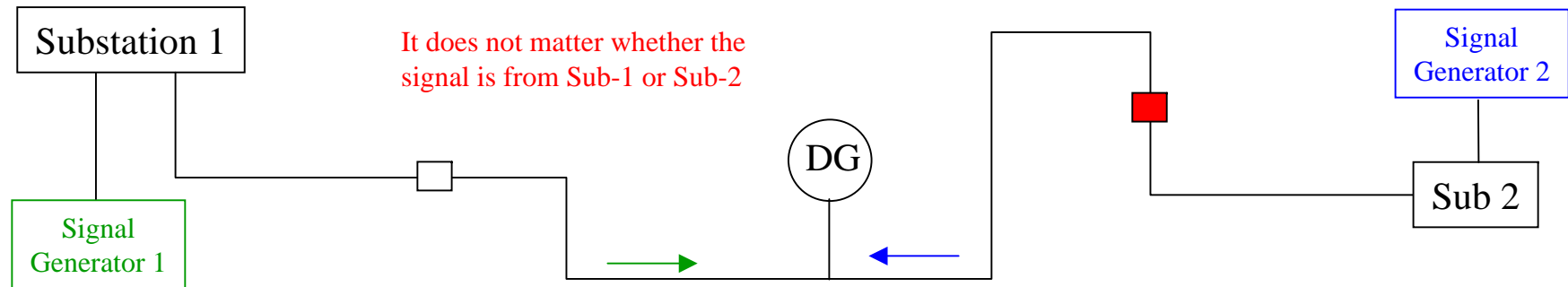

- The scheme is a fail-safe scheme

It is impossible for noises, disturbances or DGs to create a waveform pattern that resembles the signals and “holds” the DG to the system after the DG is actually islanded

- It gives utilities a full control on DG trip

The supply utility has a full control on DG connection – It can trip all DGs connected to a particular substation by simply stop broadcasting the signal using a substation SCADA commend

Main attractions - 3

- Speed of response
 - Two cycles are needed to carry one pulse
 - If missing one pulse is considered as islanding condition, the scheme can respond in 2 cycles
 - The above set up is too sensitive and are likely to cause excessive nuisance trips
 - Based on requirements of some utilities, our proposed set up is 1 pulse for every four cycles and missing 4 consecutive pulses constituting an islanded condition. So the response time is 16 cycles (or 277ms) plus breaker activation time.
- Trip DGs under single-phase lock out condition

The package provided to utilities can send signals in three phases. If any one of the phases misses the signal (i.e. 4 pulses), the signal detector will send a trip command
- The scheme can be tested without actually islanding the system
- It works on all types of DGs, independent of the natures of the DGs

Field experiences - ATCO

Test in ATCO Electric System
(Completed in 2006)



Signal generator

Field experiences - Manitoba

**Test in Manitoba Hydro system
(Completed in 2009
Report will be available in Oct 2009)**

**Signal transformer
(standard distribution transformer)**

Signal generator



Field experiences - Manitoba

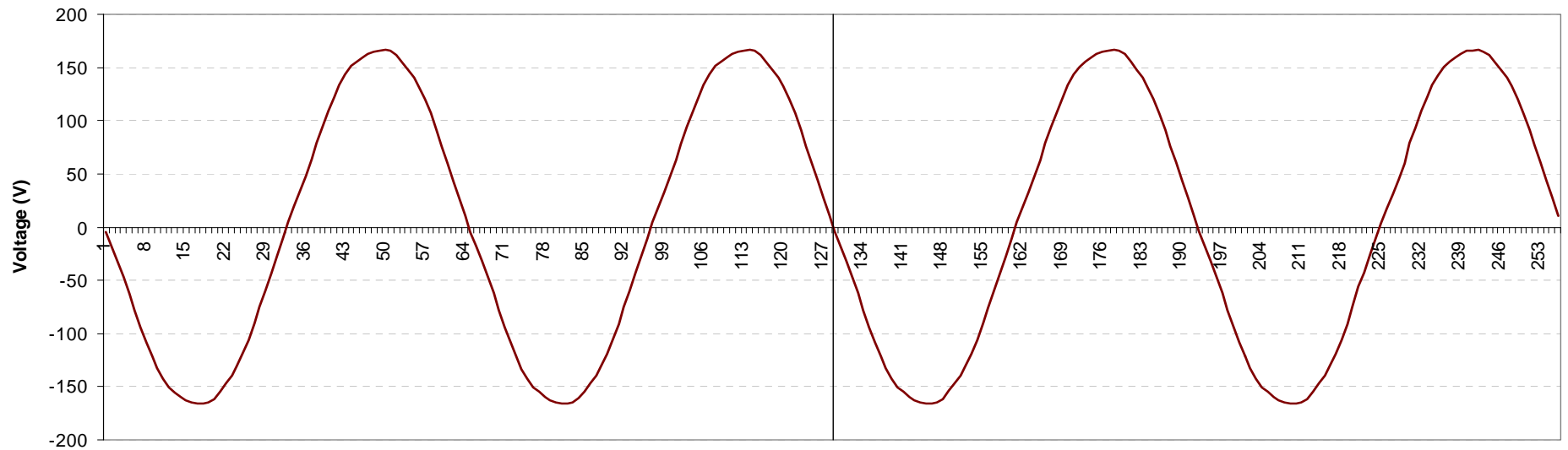

Samples (64/cycle)

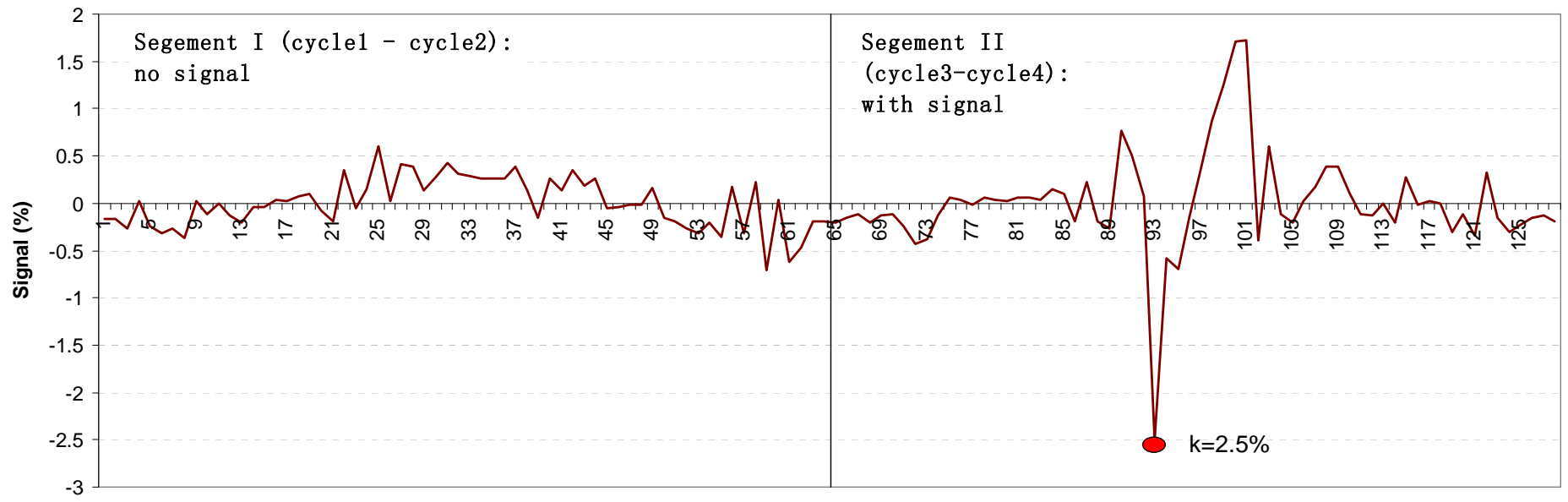

Samples (64/cycle)

Field experiences - Manitoba

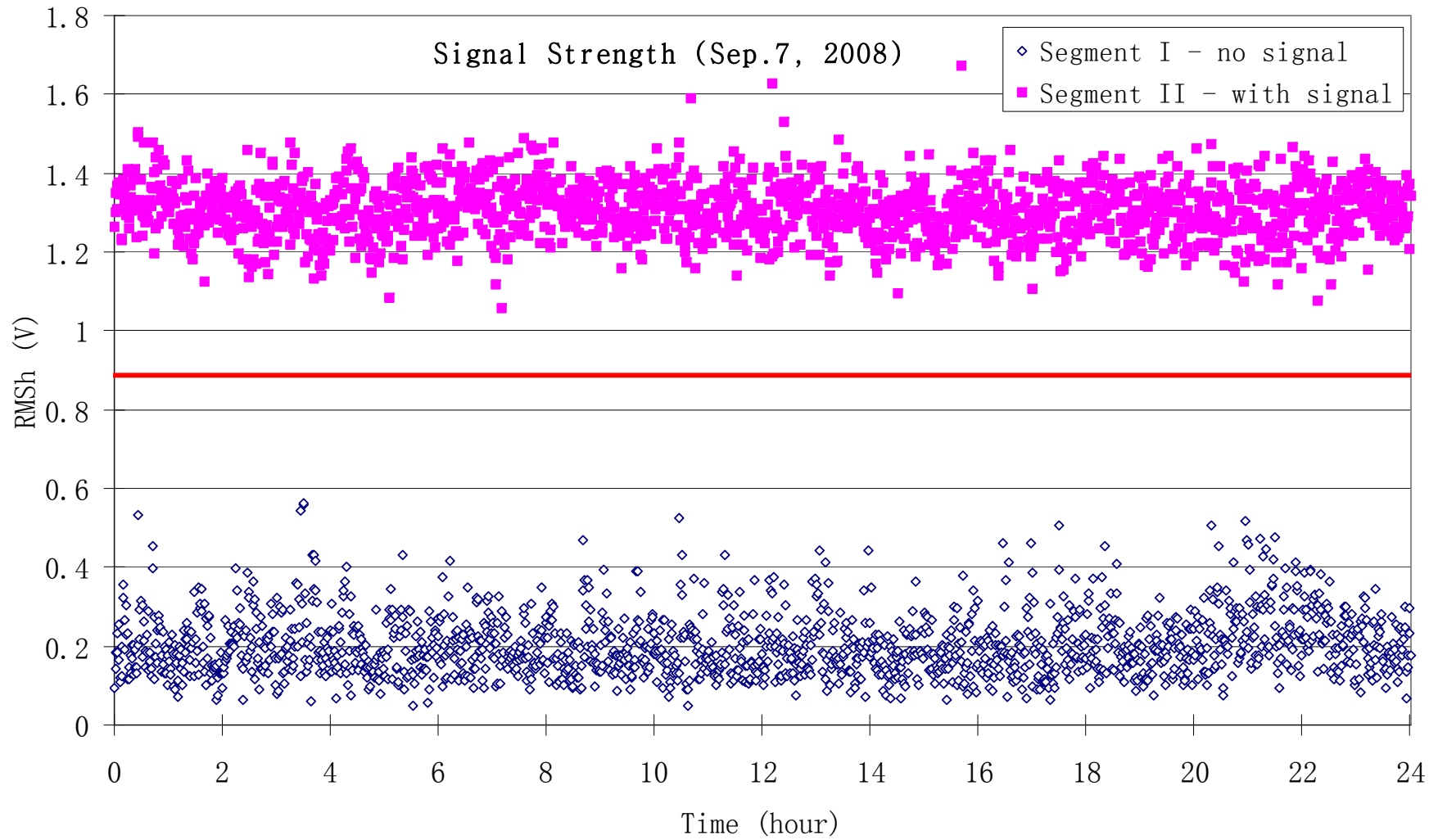

Power quality impact 1 - Interharmonics

The signaling scheme does NOT produce harmonics. It produces interharmonic-type waveform distortion. The distortion is interharmonic because not every cycle of the waveform is distorted.

The following figure shows the highest interharmonic voltage and its frequency as functions of the signal strength (k). For reliable anti-islanding application, $k=4\sim 5\%$ will be used. This gives an interharmonic level less than 0.2% and the corresponding interharmonic frequency above 350Hz.

The latest IEEE Std. 519 (to be published in 2010) does not have limits on interharmonics above 120Hz. Below 120Hz, the guideline limit varies from 0.23% to 3% (see next page).

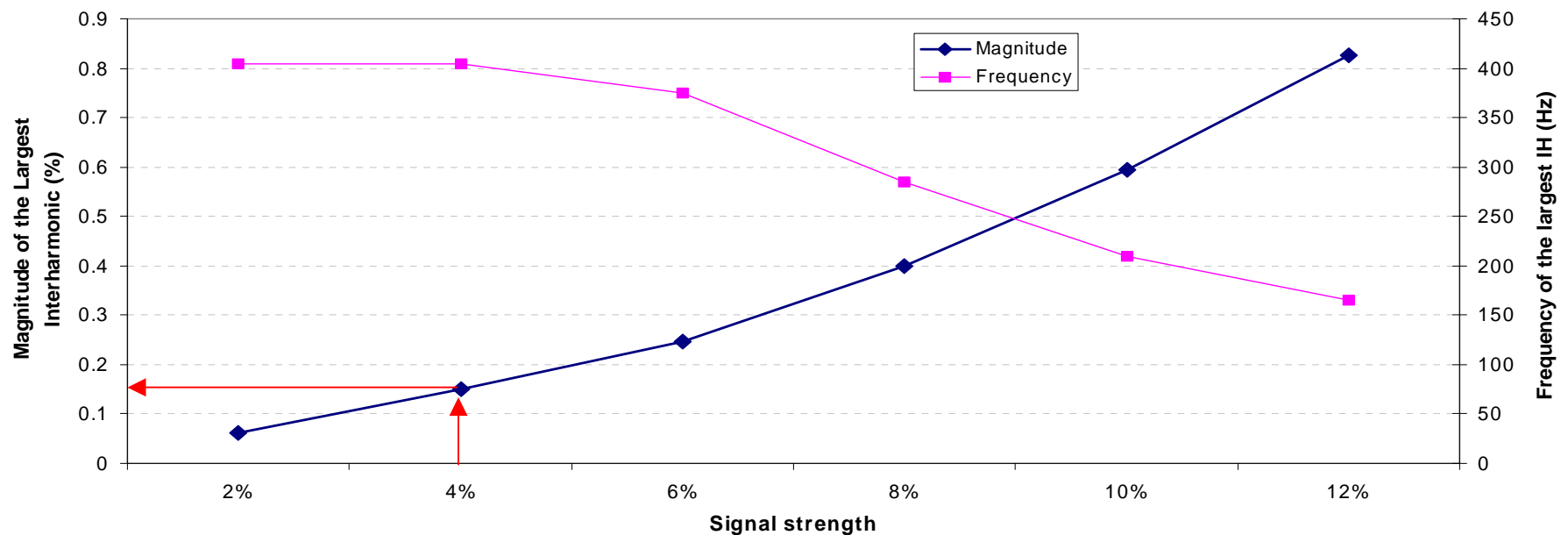

Power quality impact 1 - Upcoming IEEE Std. 519 limit on interharmonics

2/11/2007 5/24/2006

IEEE Std 519-2006

Annexes

(These informative annexes are not a part of IEEE Std 519-2005, IEEE Recommended Practices and Requirements for Harmonic Control in Electrical Power Systems, but are included for information only.)

Annex A Interharmonic Voltage Limits Based on Flicker

For harmonic components which are not integer multiples of the power frequency, system owners or operators may limit the weekly 95th percentile short time harmonic voltages to the values shown graphically in Figure A-1 up to 120 Hz. Depending on the voltage level, the integer harmonic limits in Table 5-1 may be more restrictive and should be used. The portions of the 0-120 Hz range where the integer harmonic limits of Table 5-1 are more restrictive are appropriately labeled in Figure A-1. The numerical values corresponding to Figure A-1 are given in Table A-1 for voltages at the PCC less than 1 kV. It is important to note that the suggested voltage interharmonic limits are based on lamp flicker assessed using the measurement technique described in IEEE Std. 1453 and IEC Std. 61000-4-15. These voltage interharmonic limits correlate with a short-term flicker severity Pst value equal to 1.0. The recommended limits in Figure A-1 are not based on the effects of interharmonics on other equipment and systems such as generator mechanical systems, motors, transformers, signaling and communication systems, and filters. Due consideration should be given to these effects and appropriate interharmonic current limits should be developed on a case-by-case basis using specific knowledge of the supply system, connected user loads, and provisions for future users.

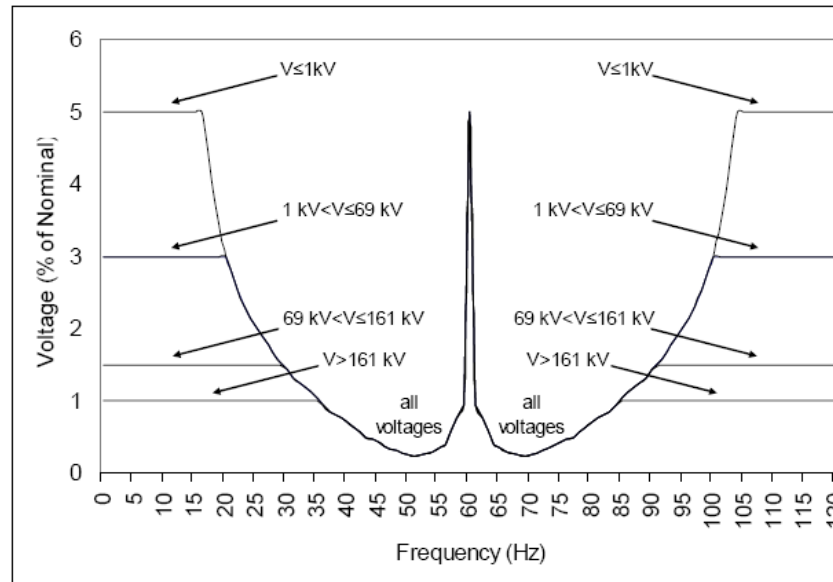
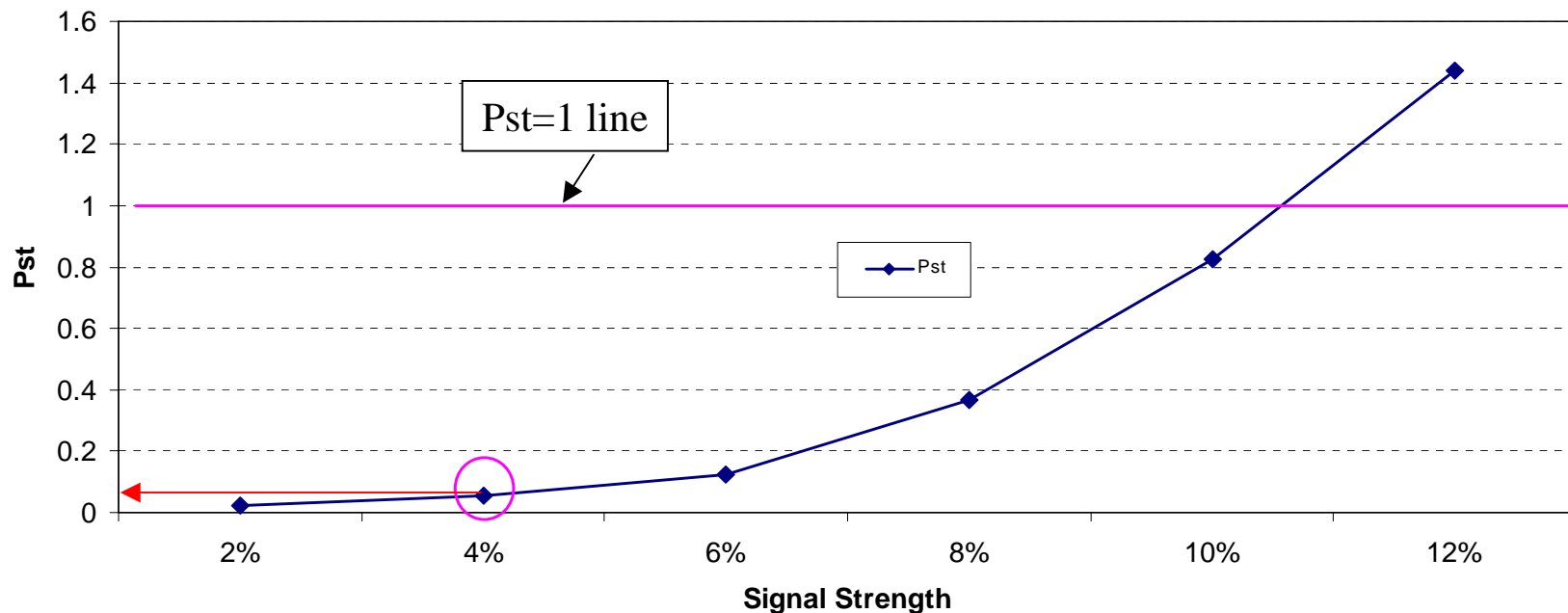

Figure A-1—Interharmonic Voltage Limits Based on Flicker for Frequencies up to 120 Hz.

Power quality impact 2: Voltage Flicker

The interharmonics could cause voltage flicker. The following figure shows that the signaling scheme will not result in P_{st} greater 1 when the signal strength is less than 10%. This means that the signaling scheme which has a signal strength of 4~5% will not cause flicker problem.



In summary, the anti-islanding signaling scheme will not cause power quality problems. This conclusion is supported by 20 plus years of field experiences of the TWACS technology.

Final word - a component of smart grid and smart meter

- The proposed scheme can be integrated into the TWACS AMR system, becoming one of the AMI features
- The scheme can also be developed independent of the TWACS to send information (not just signals) to DG for advanced DG control, such as asking DGs to output more reactive power
- The signal detector can be implemented into smart meters for the anti-islanding protection of home-based DGs such as solar panels and backyard wind turbines. This approach will enable the host utility to have a uniform, predictable and fully-controllable anti-islanding scheme for all DGs in its system – power to the utility!

For more information on these or other
products & services email us at:

sales@enertiaengineering.com



Unit #105, 117 Pembina Road
Sherwood Park, AB, Canada
T8H 0J4

Phone: 780-467-0303
Toll Free: 866-796-0303
Fax: 780-401-3519

7 Cedar Street, Suite 203
Sudbury, ON, Canada
P3B 4H5

Phone: 705-693-4829
Toll Free: 1-877-693-482

627A Aljunied Road
#04-01 BizTech Centre
Singapore 389842

Phone: (65) 64814106